



*Most Widely Accepted and Trusted*

**ESR-4395**

Issued 04/2019

This report is subject to renewal 04/2020.

# ICC-ES Evaluation Report

ICC-ES | (800) 423-6587 | (562) 699-0543 | [www.icc-es.org](http://www.icc-es.org)

**DIVISION: 07 00 00—THERMAL AND MOISTURE PROTECTION**

**SECTION: 07 32 13—CLAY ROOF TILES**

**REPORT HOLDER:**

**CLAY TILE VENTURE, INC. DBA REDLAND CLAY TILE**

**EVALUATION SUBJECT:**

**REDLAND CLAY ROOF TILES: CAMBRIDGE, TWO-PIECE MISSION, TWO-PIECE BAJA MISSION, “S,” NAPA “S,” CABRILLO “S,” ROMAN PAN, TWO-PIECE JUNIPERO, ALFARO AND TWO-PIECE ANGULO TILES**



*“2014 Recipient of Prestigious Western States Seismic Policy Council (WSSPC) Award in Excellence”*



*ICC-ES Evaluation Reports are not to be construed as representing aesthetics or any other attributes not specifically addressed, nor are they to be construed as an endorsement of the subject of the report or a recommendation for its use. There is no warranty by ICC Evaluation Service, LLC, express or implied, as to any finding or other matter in this report, or as to any product covered by the report.*



# ICC-ES Evaluation Report

**ESR-4395**

Issued April 2019

This report is subject to renewal April 2020.

[www.icc-es.org](http://www.icc-es.org) | (800) 423-6587 | (562) 699-0543

A Subsidiary of the International Code Council®

**DIVISION: 07 00 00—THERMAL AND MOISTURE PROTECTION**

**Section: 07 32 13—Clay Roof Tiles**

**REPORT HOLDER:**

**CLAY TILE VENTURE, INC. DBA REDLAND CLAY TILE**

**EVALUATION SUBJECT:**

**REDLAND CLAY ROOF TILES: CAMBRIDGE, TWO-PIECE MISSION, TWO-PIECE BAJA MISSION, “S,” NAPA “S,” CABRILLO “S,” ROMAN PAN, TWO-PIECE JUNIPERO, ALFARO AND TWO-PIECE ANGULO TILES**

**1.0 EVALUATION SCOPE**

**Compliance with the following codes:**

- 2018, 2015, 2012, 2009 and 2006 *International Building Code*® (IBC)
- 2018, 2015, 2012, 2009 and 2006 *International Residential Code*® (IRC)

**Properties evaluated:**

- Wind uplift resistance
- Fire classification
- Durability

**2.0 USES**

The Redland Clay Tile roof tiles, when installed in accordance with this report, are Class A roof coverings in accordance with the IBC and the IRC.

**3.0 DESCRIPTION**

**3.1 General:**

Redland Clay Tile roof tiles are composed of vitrified clay, and kiln-fired at various temperatures for different burnt-on colors. The tiles comply with ASTM C1167.

**3.2 Cambridge Tile:**

The tiles are flat and are approximately 15 inches (381 mm) long, 6<sup>3</sup>/<sub>4</sub> inches (171 mm) wide and 5<sup>5</sup>/<sub>8</sub> inch (15.9 mm) thick, and weigh 4.75 pounds (2.14 kg) each. Two nail holes are provided in the top portion of each tile. The tiles have an installed weight of 14.7 pounds per square foot (71.8 kg/m<sup>2</sup>) when installed with a 6<sup>1</sup>/<sub>2</sub>-inch exposure. The tiles are Type III, Grade 2, in accordance with ASTM C1167. See Figure 1 for details.

**3.3 Two-piece Mission Tile:**

Top and pan tiles are curved to approximately one-third of a circle, and have widths at the large and small ends of

approximately 8<sup>1</sup>/<sub>2</sub> and 7 inches (216 and 178 mm), respectively. One nail hole is provided in the small end of the top tile and in the large end of the pan tile. Tiles are approximately 1/2 inch (12.7 mm) thick and 20 inches (508 mm) long, and weigh 10.7 pounds per square foot (52.2 kg/m<sup>2</sup>) when installed with a maximum 11-inch (279 mm) center-to-center spacing, and a headlap of 3 inches (76 mm). The tiles may be used as hip, ridge and rake tiles for all tile profiles described in this report, provided they are embedded in mortar or roofing mastic. The tiles are Type I – high-profile, Grade 2, in accordance with ASTM C1167. See Figure 2 for details.

**3.4 Two-piece Baja Mission Tile:**

The tiles are similar to the two-piece Mission Tile, except that the widths at the large and small ends are approximately 6<sup>3</sup>/<sub>4</sub> and 6 inches (171 and 152 mm), respectively. Tiles are approximately 1/2 inch (12.7 mm) thick and 17<sup>1</sup>/<sub>2</sub> inches (445 mm) long. The installed weight of the tiles, when installation is with a 9-inch (229 mm) center-to-center spacing, and a headlap of 3 inches (76 mm), is 9.4 pounds per square foot (45.9 kg/m<sup>2</sup>). The tiles may also be used as hip, ridge and rake tiles for all tile profiles described in this report, provided they are embedded in mortar or roofing mastic. The tiles are Type I – high-profile, Grade 2, in accordance with ASTM C1167. See Figure 2 for details.

**3.5 “S” Tile:**

The tiles are single S-shaped tiles manufactured in a manner similar to the two-piece Mission Tiles, except they are 18 inches (457 mm) long, 13 inches (330 mm) wide and 1/2 inch (12.7 mm) thick, with two nail holes in the pan tile and one nail hole in the cover tile. The installed tile weight is 9 pounds per square foot (43.9 kg/m<sup>2</sup>) when installation is with an 11-inch (279 mm) center-to-center spacing and a 3-inch (76 mm) headlap. The tiles are Type I – high-profile, Grade 2, in accordance with ASTM C1167. See Figure 3 for details. Mission hip and ridge tiles, as shown in Figure 2, are curved to approximately one-third of a circle, and have widths at the large and small ends of approximately 8<sup>1</sup>/<sub>2</sub> and 7 inches (216 and 178 mm), respectively.

**3.6 Napa “S” Tile:**

The Napa “S” Tile is approximately 13<sup>3</sup>/<sub>4</sub> inches (349 mm) long, 10<sup>1</sup>/<sub>2</sub> inches (267 mm) wide and 1/2 inch (12.7 mm) to 5<sup>5</sup>/<sub>8</sub> inch (15.9 mm) thick. The barrel portion of the tile rises 2<sup>5</sup>/<sub>16</sub> inches (58 mm) over a span of 6.45 inches (164 mm). The tile has a flat pan section approximately 2<sup>5</sup>/<sub>16</sub> inches (58 mm) wide, and the edge ends in a 45-degree flared lip.

Two nail holes are located on the pan section and one nail slot is located on the barrel. The installed weight of the tiles is 10.5 pounds per square foot (51.3 kg/m<sup>2</sup>) when installation is with an 8<sup>1</sup>/<sub>2</sub>-inch (216 mm) center-to-center spacing and a 3-inch (76 mm) headlap. The tiles are Type I – high-profile, Grade 1, in accordance with ASTM C1167. See Figure 4 for details.

### 3.7 Cabrillo “S” Tile:

The Cabrillo “S” Tile is approximately 20 inches (508 mm) long, 12<sup>1</sup>/<sub>2</sub> inches (318 mm) wide and <sup>1</sup>/<sub>2</sub> inch (12.7 mm) thick. The barrel portion of the tile rises 3 inches (76 mm) over a span of 8.5 inches (216 mm). The tile has a flat pan section approximately 2 inches (51 mm) wide, and the edge ends in a 45-degree flared lip. Two nail holes are located on the pan section and one nail slot is located on the barrel. The installed weight of the tiles is 7.5 pounds per square foot (36.6 kg/m<sup>2</sup>) when installation is with an 11-inch (279 mm) center-to-center spacing and a 3-inch (76 mm) headlap. The tiles are Type I – high-profile, Grade 2, in accordance with ASTM C1167. See Figure 8 for details.

### 3.8 Roman Pan:

The tiles are 17<sup>3</sup>/<sub>4</sub> inches (451 mm) long, 11 inches (279 mm) wide, <sup>5</sup>/<sub>8</sub> inch (15.9 mm) thick and 2<sup>3</sup>/<sub>8</sub> inches (60 mm) in height to the outer edge of the side lip. Two nail holes are centered approximately 1<sup>1</sup>/<sub>2</sub> inches (38 mm) from the tile head and are spaced 5<sup>1</sup>/<sub>4</sub> inches (133 mm) apart. The cover tile and pan tile are similar except that the nail holes are located on opposite ends. The installed weight of the tiles is 10.1 pounds per square foot (49.3 kg/m<sup>2</sup>) when installation is with an 18-inch (457 mm) center-to-center spacing and with a headlap of 3 inches (76 mm). The tiles are Type I – high-profile, Grade 2, in accordance with ASTM C1167. See Figure 5 for details.

### 3.9 Two-piece Junipero Tile:

The Junipero Pan Tile is a tapered clay tile approximately 16<sup>3</sup>/<sub>4</sub> inches (425 mm) long and <sup>1</sup>/<sub>2</sub> inch (12.7 mm) thick, and has widths at the small and large ends of approximately 5<sup>3</sup>/<sub>4</sub> inches (146 mm) and 7 inches (178 mm), respectively. The height of the tile is approximately 3 inches (76 mm). One nail slot is located approximately 1 inch (25.4 mm) from the head of the tile.

The Junipero Cover Tile has a finger-embossed design on the surface and is designed to be used with the Junipero Pan Tile. The cover tile is similar to the Junipero Pan Tile except that the widths at the small and large ends are approximately 5<sup>3</sup>/<sub>4</sub> inches (146 mm) and 7 inches (178 mm), respectively. The height of the cover tile is approximately 3 inches (64 mm). One fastener slot is located approximately 1 inch (25.4 mm) from the head of the tile.

The tiles are installed with a headlap of 3 inches (76 mm) and have an installed weight of 14 pounds per square foot (68 kg/m<sup>2</sup>) when installation is with a 9-inch (229 mm) center-to-center spacing. The tiles are Type I – high-profile, Grade 2, in accordance with ASTM C1167. See Figure 6 for details.

### 3.10 Alfaro Tile:

The Alfaro Tile is approximately 18 inches (457 mm) long and 10 inches (254 mm) wide, with a thickness of <sup>1</sup>/<sub>2</sub> inch (12.7 mm) to <sup>9</sup>/<sub>16</sub> inch (14.3 mm). The height of the barrel portion of the tile is approximately 1<sup>13</sup>/<sub>16</sub> inches (46 mm). The tile has a flat pan section approximately 3 inches (76 mm) wide, and two side lips that flare 45 degrees. Opposite corners are cut to a triangular shape. Two nail holes are located on the pan section and one nail slot is

located on the barrel. Tiles are installed with a 3-inch (76 mm) headlap and have an installed weight of 8.1 pounds per square foot (39.5 kg/m<sup>2</sup>) when installation is with an 8-inch (203 mm) center-to-center spacing. The tiles are Type I – high-profile, Grade 2, in accordance with ASTM C1167. See Figure 7 for details.

### 3.11 Two-Piece Angulo Tile:

The top and pan tiles are curved to approximately one third of a circle and are approximately 18<sup>1</sup>/<sub>2</sub> inches (470 mm) long and <sup>1</sup>/<sub>2</sub> inch (12.7 mm) thick. The tiles have widths at the large and small ends of approximately 7<sup>1</sup>/<sub>4</sub> inches (184 mm) and 6 inches (152 mm), respectively. The height of the tile is approximately 3.65 inches (93 mm). The cover and pan tiles are similar except that the nail holes are located on opposite ends, approximately 1 inch (25.4 mm) from the head of the tile.

The tiles are installed with a headlap of 3 inches (76 mm) and have an installed weight of 13 pounds per square foot (63 kg/m<sup>2</sup>) when installation is with a 9-inch (229 mm) center-to-center spacing. The tiles may be used as hip, ridge and rake tiles for all tile profiles described in this report, provided they are embedded in mortar or roofing mastic. The tiles are Type I – high-profile, Grade 2, in accordance with ASTM C1167. See Figure 9 for details.

## 4.0 INSTALLATION

### 4.1 General:

The tiles must be installed in accordance with IBC Section 1507.3 and IRC Section R905.3, as applicable, and the Concrete and Clay Roof Tile Installation Manual for Moderate Climate Regions, dated March 2010 and published by the Tile Roofing Institute and the Western States Roofing Contractors Association (hereinafter referred to as the TRI/WSRCA installation manual), except as otherwise noted in this report. This report and the TRI/WSRCA installation manual must be available at the jobsite at all times during installation.

Flashing must be in accordance with IBC Sections 1503.2 and 1507.3.9, or IRC Sections R903.2 and R905.3.8, as applicable.

**4.1.1 Cambridge Tile:** The tiles must be installed at a maximum 6<sup>1</sup>/<sub>2</sub>-inch (165 mm) exposure. The tiles must be placed with gaps in adjacent courses staggered a minimum of 1<sup>1</sup>/<sub>2</sub> inches (38 mm), and spacing between tiles in each course must be approximately <sup>3</sup>/<sub>8</sub> inch (9.5 mm). Each tile must be fastened using two No. 11 gage, corrosion-resistant roofing nails having a 0.121 inch-diameter (3.07 mm) shank and a <sup>5</sup>/<sub>16</sub>-inch-diameter head (7.9 mm) and having sufficient length to penetrate the sheathing at least <sup>3</sup>/<sub>4</sub> inch (19 mm), or to extend through the sheathing, whichever is less. See Figure 1 for details.

### 4.2 Hip and Ridge Tile:

Nailer boards of sufficient height to adequately support hip or ridge tiles must be fastened to framing with two corrosion-resistant 10d nails at 24 inches (610 mm) on center, or must be secured using galvanized steel strapping or special galvanized attachment devices at 48 inches (1219 mm) on center. One layer of ASTM D226, Type II (No. 30), underlayment must be applied over the ridge nailer board prior to installation of the hip and ridge tile. Each hip and ridge tile must be attached to the nailer board with one No. 11 gage, corrosion-resistant roofing nail with a 0.121 inch-diameter (3.07 mm) shank, a <sup>5</sup>/<sub>16</sub>-inch-diameter head (7.9 mm), and sufficient length to penetrate a minimum of <sup>3</sup>/<sub>4</sub> inch (19 mm) into the nailer board. Roofer's mastic or tile adhesive, specified by Redland Clay Tile, must be applied at hip and ridge

headlaps to cover the nail hole and create a bond between the tiles.

#### 4.3 Roof Slope Limitations:

Tiles must be installed on roof slopes between 3:12 (25%) and 21:12 (173%).

#### 4.4 Underlayment:

Underlayment must comply with, and be installed in accordance with, the applicable code.

#### 4.5 Roof Classification:

**4.5.1 2018, 2015, 2012 and 2009 IBC and IRC:** The Redland Clay Tile roof tiles installed in accordance with this report are Class A roof coverings in accordance with 2018, 2015, 2012 and 2009 IBC Section 1505.2, and 2018, 2015, 2012 and 2009 IRC Section R902.1. The tiles must be installed over one layer of underlayment complying with ASTM D226, Type II (No. 30).

**4.5.2 2006 IBC and IRC:** The Redland Clay Tile roof tiles installed in accordance with this report are Class A roof coverings in accordance with the exception to 2006 IBC Section 1505.2 and 2006 IRC Section R902.1.

#### 4.6 Reroofing Applications:

**4.6.1 2018, 2015, 2012 and 2009 IBC and IRC:** When installation is over existing roofs, the existing roof covering and underlayment must be completely removed and the tiles and new underlayment must be installed in accordance with Section 4.0 of this report. An existing self-adhered ice barrier may remain in place if covered with a new ice barrier membrane in accordance with the applicable code. The roof classification is as noted in Section 4.5.1.

**4.6.2 2006 IBC and IRC:** The tiles are permitted to be installed over existing roofs, provided the requirements of IBC Section 1510 or IRC Section R907, as applicable, are met. The roof classification is as noted in Section 4.5.2.

#### 4.7 Wind Resistance:

**4.7.1 2018 IBC and 2018 IRC:** When installed in accordance with this report, the Redland Clay Tile roof tiles are limited to areas subject to a maximum basic design wind speed ( $V$ ) of 130 mph (209 km/h) on structures having a maximum mean roof height of 60 feet (18.3 m) for the IBC or a maximum ultimate design wind speed ( $V_{ult}$ ) of 130 mph (209 km/h) and a maximum mean roof height of 40 feet (12.2 m) for the IRC.

**4.7.2 2015 IBC, 2015 IRC and 2012 IBC:** When installed in accordance with this report, the Redland Clay Tile roof tiles are limited to areas subject to a maximum ultimate design wind speed ( $V_{ult}$ ) of 130 mph (209 km/h) on structures having a maximum mean roof height of 60 feet (18.3 m) for the IBC and a maximum mean roof height of 40 feet (12.2 m) for the IRC.

**4.7.3 2009 and 2006 IBC:** When installed in accordance with this report, the Redland Clay Tile roof tiles are limited to areas subject to a maximum basic wind speed of 100 mph (161 km/h), on structures having a maximum mean roof height of 60 feet (18.3 m)

**4.7.4 2012, 2009 and 2006 IRC:** When installed in accordance with this report, the Redland Clay Tile roof tiles are limited to areas subject to a maximum basic wind speed of 100 mph (161 km/h) on structures having a maximum mean roof height of 40 feet (12.2 m).

## 5.0 CONDITIONS OF USE

The Redland Clay Tile roof tiles described in this report comply with, or are suitable alternatives to what is specified in, those codes listed in Section 1.0 of this report, subject to the following conditions:

- 5.1 The tiles must be manufactured, identified and installed in accordance with this report, the applicable code, and the TRI/WSRCA installation manual, dated March 2010. The instructions within this report govern if there are any conflicts between the TRI/WSRCA installation manual and this report.
- 5.2 The tiles are limited to use in those areas described in Section 4.7 of this report.
- 5.3 The roof sheathing and roof framing system must be designed for the appropriate loads determined in accordance with the applicable code, subject to the approval of the code official.
- 5.4 The tiles are manufactured in Tecate, Baja California, Mexico, under a quality-control program with inspections by ICC-ES.

## 6.0 EVIDENCE SUBMITTED

Data in accordance with the ICC-ES Acceptance Criteria for Clay and Concrete Roof Tiles (AC180), dated February 2012 (editorially revised April 2015).

## 7.0 IDENTIFICATION

- 7.1 Each tile is embossed with the words "Redland, Mexico." In addition, each pallet is identified with the evaluation report number (ESR-4395), the Redland Clay Tile name, the product name, the manufacturing location (Tecate, Mexico) and the installed weight.
- 7.2 The report holder's contact information is the following:

**CLAY TILE VENTURE. INC. DBA REDLAND CLAY TILE**  
**9155 BROWN DEER ROAD, SUITE 5**  
**SAN DIEGO, CALIFORNIA 92121**  
**(858) 622-1935**  
[www.redlandclaytile.com](http://www.redlandclaytile.com)

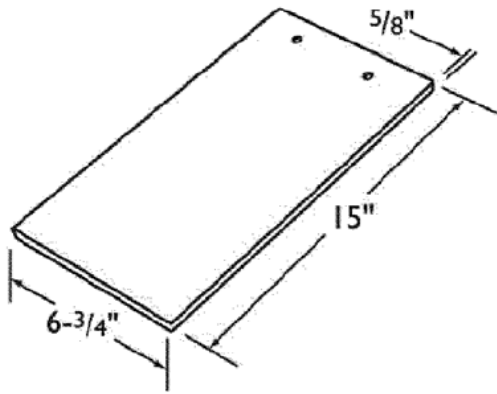

Cambridge Shingle Tile

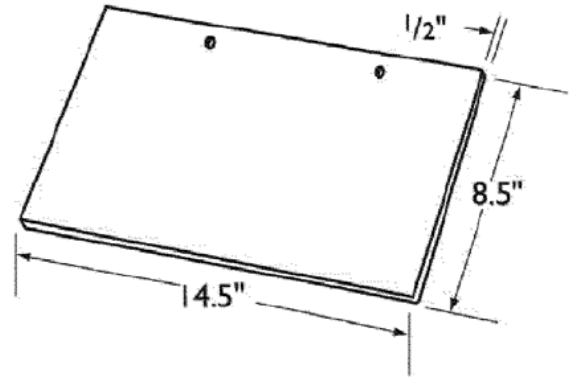

Cambridge Starter Tile

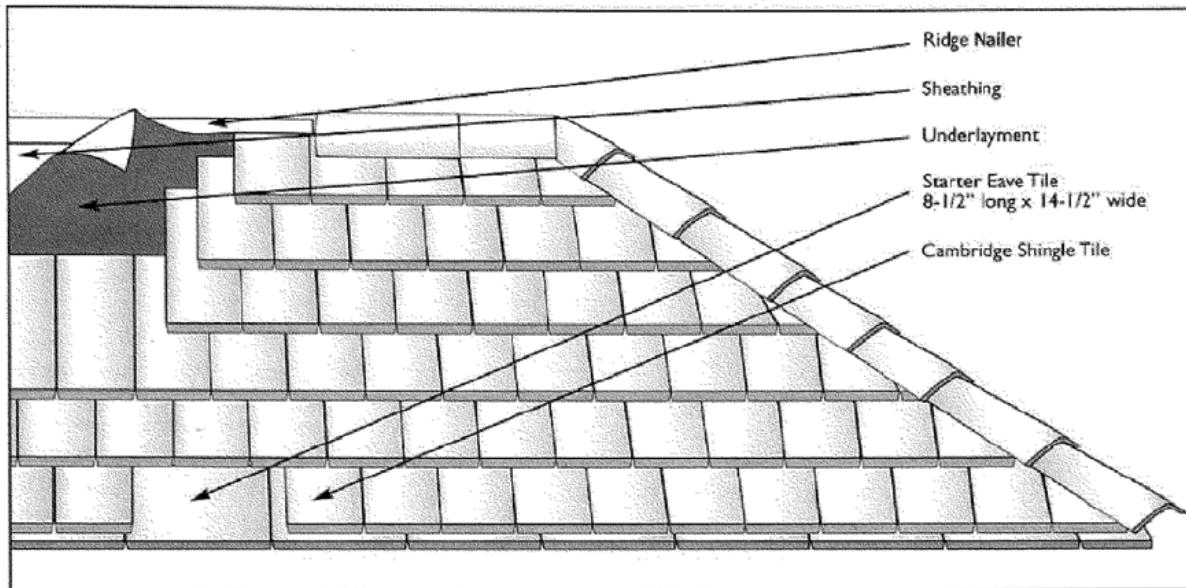

For SI: 1 inch = 25.4 mm.

FIGURE 1—CAMBRIDGE TILE

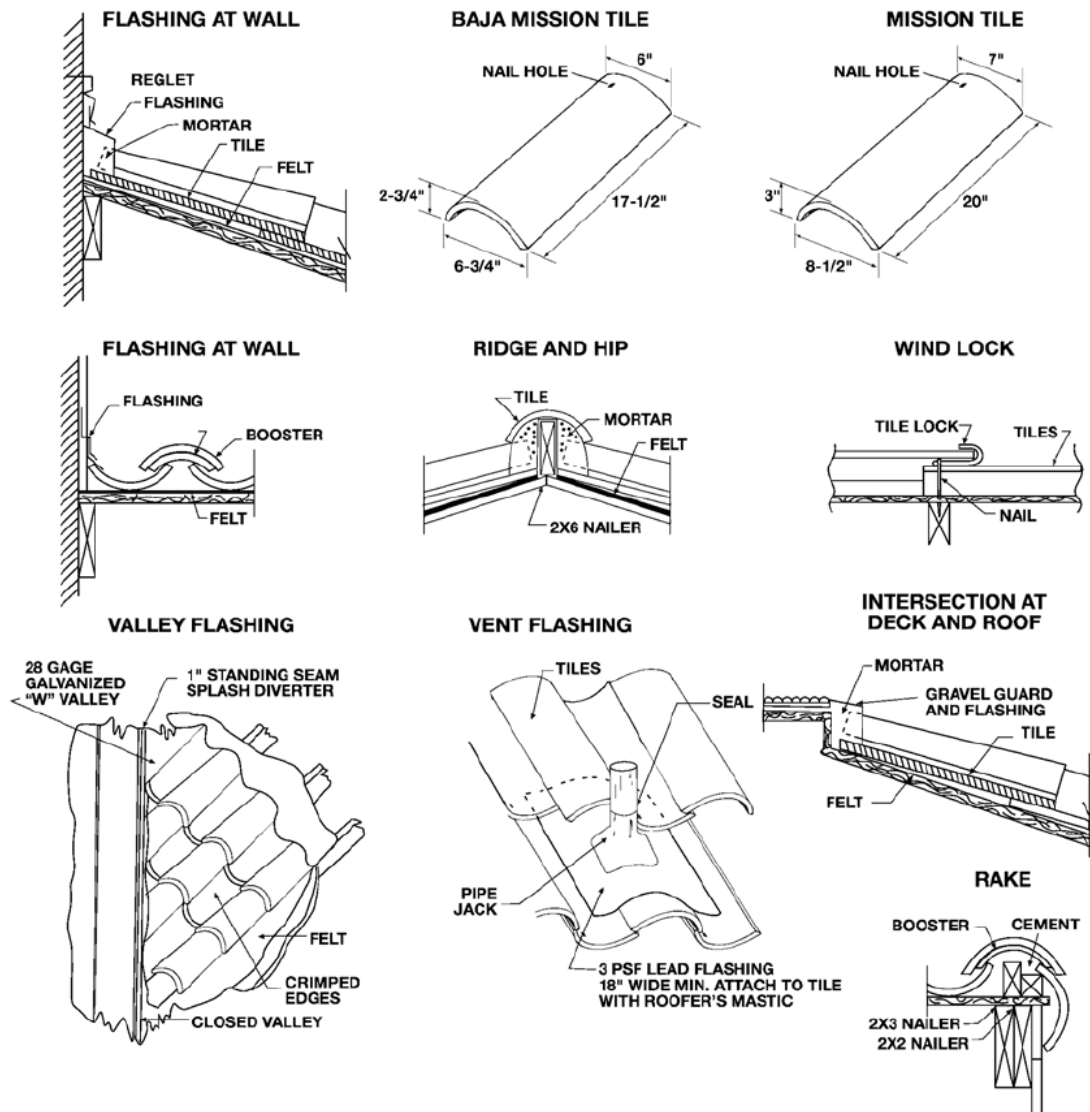
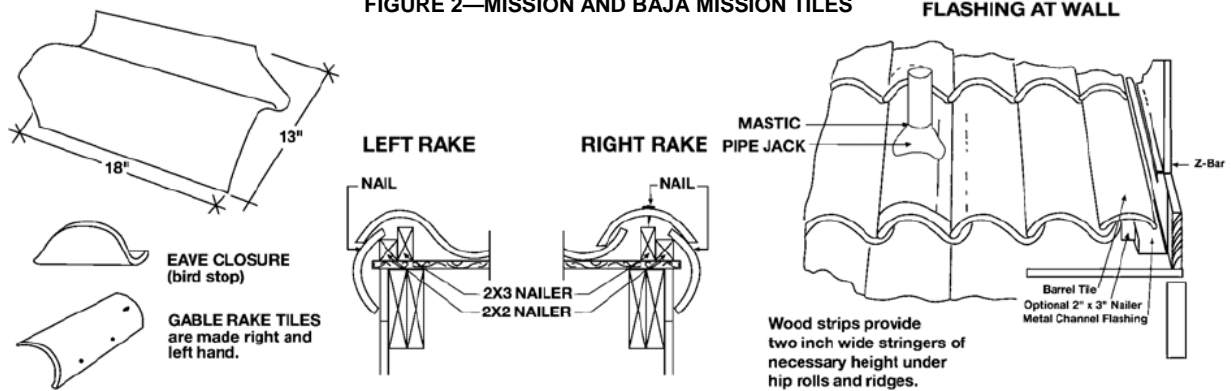

FIGURE 2—MISSION AND BAJA MISSION TILES



FLASHING AT WALL

LEFT RAKE

RIGHT RAKE

Wood strips provide two inch wide stringers of necessary height under hip rolls and ridges.

For SI: 1 inch = 25.4 mm.

FIGURE 3—"S" TILE

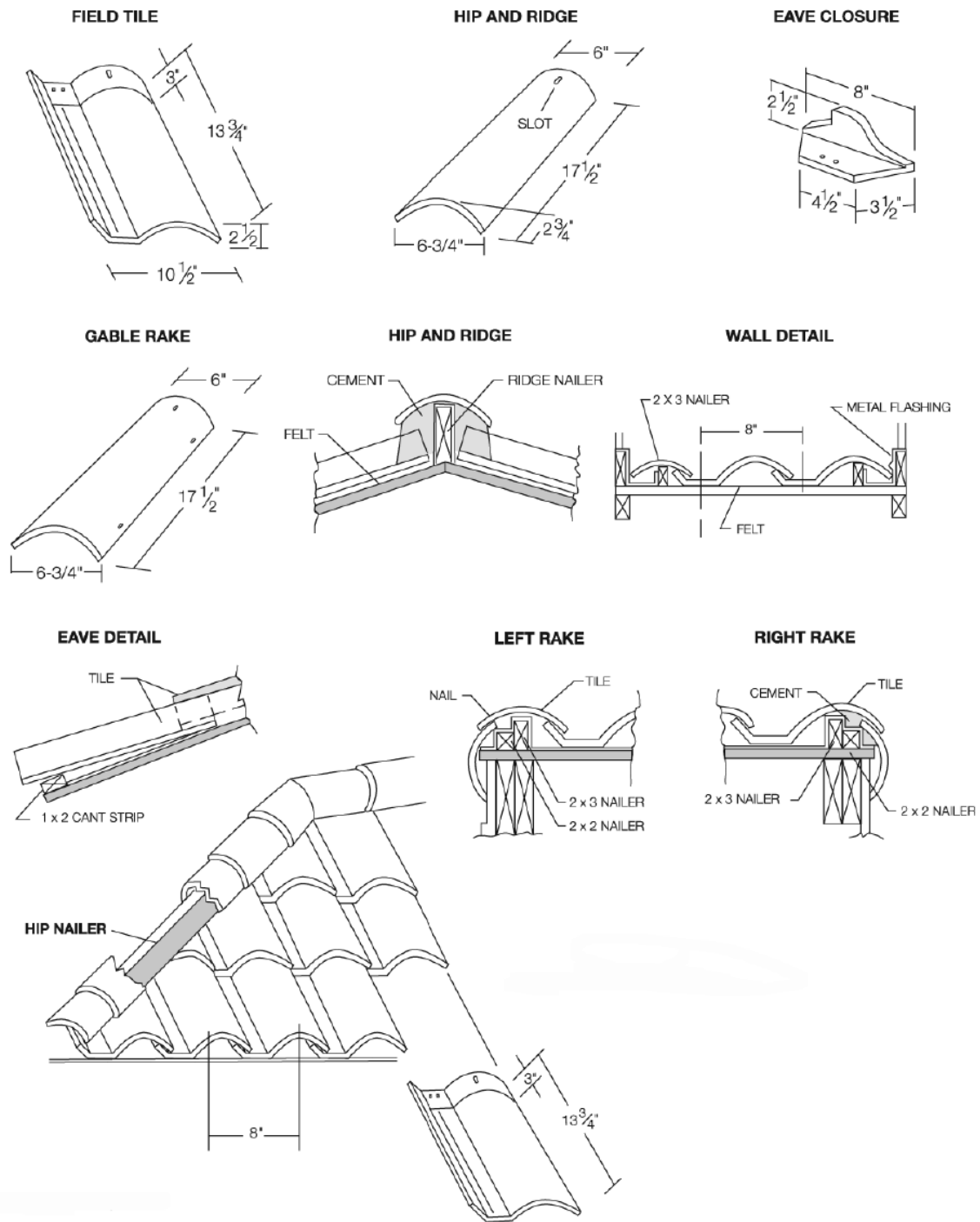

For SI: 1 inch = 25.4 mm.

FIGURE 4—NAPA "S" TILE

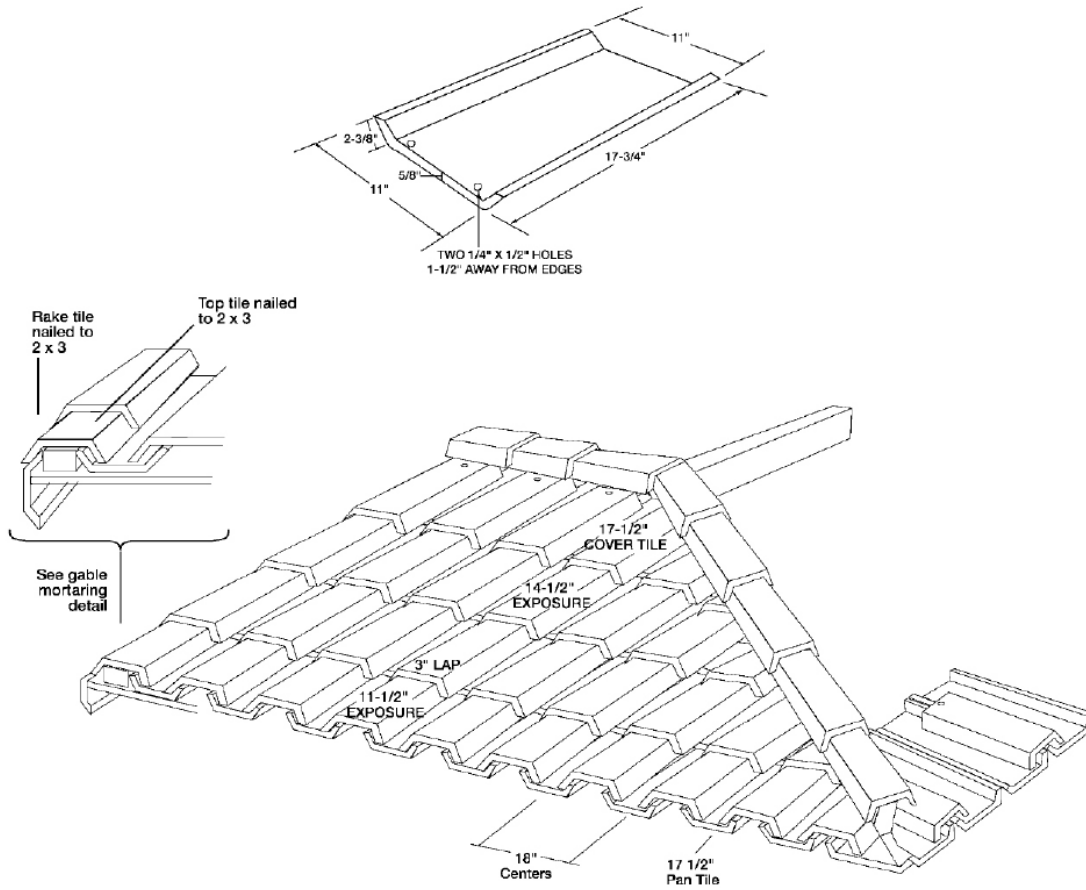

FIGURE 5—ROMAN PAN

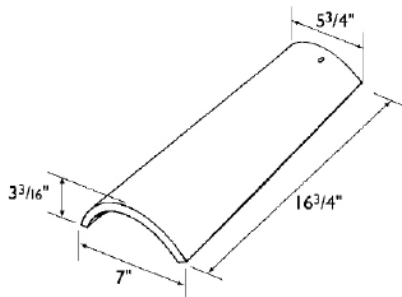

FIGURE 6—JUNIPERO TILE

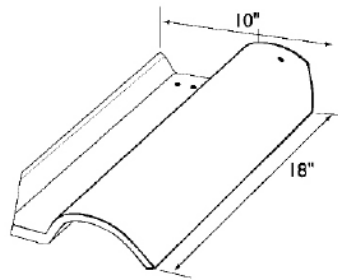

FIGURE 7—ALFARO TILE

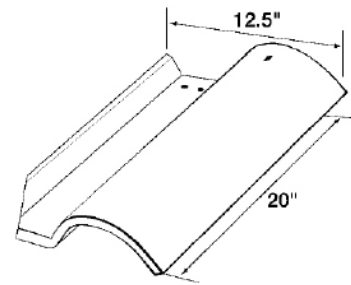

FIGURE 8—CABRILLO "S" TILE

For SI: 1 inch = 25.4 mm.

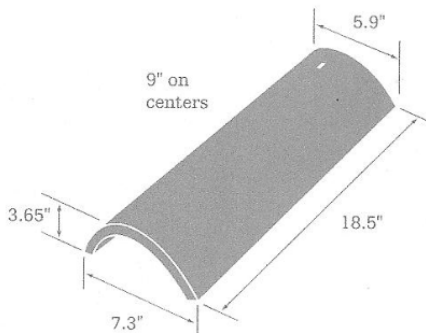

FIGURE 9—ANGULO TILE



## ICC-ES Evaluation Report

## ESR-4395 CBC and CRC Supplement

Issued April 2019

This report is subject to renewal April 2020.

[www.icc-es.org](http://www.icc-es.org) | (800) 423-6587 | (562) 699-0543

A Subsidiary of the International Code Council®

**DIVISION: 07 00 00—THERMAL AND MOISTURE PROTECTION**  
**Section: 07 32 13—Clay Roof Tiles**

### REPORT HOLDER:

CLAY TILE VENTURE, INC. DBA REDLAND CLAY TILE

### EVALUATION SUBJECT:

REDLAND CLAY ROOF TILES: CAMBRIDGE, TWO-PIECE MISSION, TWO-PIECE BAJA MISSION, "S," NAPA "S," CABRILLO "S," ROMAN PAN, TWO-PIECE JUNIPERO, ALFARO AND TWO-PIECE ANGULO TILES

### 1.0 REPORT PURPOSE AND SCOPE

#### Purpose:

The purpose of this evaluation report supplement is to indicate that Redland Clay Tile clay roofing tiles, recognized in ICC-ES master evaluation report ESR-4395, have also been evaluated for compliance with the codes noted below.

#### Applicable code editions:

- 2016 *California Building Code* (CBC)
- 2016 *California Residential Code* (CRC)

### 2.0 CONCLUSIONS

#### 2.1 CBC:

The Redland Clay Tile clay roofing tiles described in the master report ESR-4395 may be used where a Class A roof covering complying with CBC Section 1505.1.1, a Class B roof covering complying with CBC Section 1505.1.2, or a Class C roof covering complying with CBC Section 1505.1.3 is required, provided installation is in accordance with the master report and the additional requirements of CBC Sections 1507.3.10 and 1511.

The roof tiles may be used in the construction of new buildings located in a Fire Hazard Severity Zone within State Responsibility Areas or any Wildland–Urban Interface Fire Area, provided installation is also in accordance with the master report and the additional requirements of Sections 701A.3 and 705A of the CBC.

#### 2.2 CRC:

The Redland Clay Tile clay roofing tiles described in the master report ESR-4395 may be used where a Class A roof covering complying with CRC Section R902.1.1, a Class B roof covering complying with CRC Section R902.1.2, or a Class C roof covering complying with CRC Section R902.1.3 is required, provided installation is in accordance with the master report and the additional requirements of CRC Section R905.3.

The roof tiles may be used in the construction of new buildings located in any Wildland–Urban Interface Fire Area, provided installation is also in accordance with the master report and the additional requirements of Sections R337.1.3.1 and R337.5 of the CRC.

The products recognized in this supplement have not been evaluated for compliance with the *International Wildland–Urban Interface Code*®.

This supplement expires concurrently with the master report issued April 2019.

## ICC-ES Evaluation Report

## ESR-4395 FBC Supplement

Issued April 2019

This report is subject to renewal April 2020.

[www.icc-es.org](http://www.icc-es.org) | (800) 423-6587 | (562) 699-0543 A Subsidiary of the International Code Council®

**DIVISION: 07 00 00—THERMAL AND MOISTURE PROTECTION**  
**Section: 07 32 13—Clay Roof Tiles**

### REPORT HOLDER:

CLAY TILE VENTURE, INC. DBA REDLAND CLAY TILE

### EVALUATION SUBJECT:

REDLAND CLAY ROOF TILES: CAMBRIDGE, TWO-PIECE MISSION, TWO-PIECE BAJA MISSION, “S,” NAPA “S,” CABRILLO “S,” ROMAN PAN, TWO-PIECE JUNIPERO, ALFARO AND TWO-PIECE ANGULO TILES

### 1.0 EVALUATION SCOPE

#### Purpose:

The purpose of this evaluation report supplement is to indicate that the Redland Clay Tile clay roof tiles, recognized in ICC-ES master report ESR-4395, have also been evaluated for compliance with the codes noted below.

#### Applicable code editions:

- 2017 *Florida Building Code—Building*
- 2017 *Florida Building Code—Residential*

### 2.0 CONCLUSIONS

The clay roof tiles, described in Sections 2.0 through 7.0 of the master evaluation report ESR-4395, comply with the *Florida Building Code—Building* and the *Florida Building Code—Residential*, provided the design and installation are in accordance with the *International Building Code*® (IBC) provisions noted in the master report, with this additional condition: the roof tiles must be installed in accordance with Section 1609 of the 2017 *Florida Building Code—Building* or with FRSA/TRI Florida High Wind Concrete and Clay Roof Tile Installation Manual, Fifth Edition Revised.

Use of the clay roof tiles described in the master evaluation report for compliance with the High-Velocity Hurricane Zone provisions of the *Florida Building Code—Building* and the *Florida Building Code—Residential* has not been evaluated, and is outside the scope of this evaluation report.

For products falling under Florida Rule 9N-3, verification that the report holder’s quality-assurance program is audited by a quality-assurance entity approved by the Florida Building Commission for the type of inspections being conducted is the responsibility of an approved validation entity (or the code official when the report holder does not possess an approval by the Commission).

This supplement expires concurrently with the master report issued April 2019.